



RAMP SAFETY

Scotgrip® HD Anti-Slip Stepmate® Bridges & Ramps

Scotgrip® HD anti-slip Stepmate® pipe/cable bridges and ramps incorporate the unique Scotgrip® high-traction anti-slip safety surface which gives a sound foot-holding in the most extreme conditions. These heavy duty, tough and durable products are manufactured under BS EN ISO 9001:2015 quality controlled conditions comprising of a reinforced composite base and a graded aggregate surface. As a Scotgrip® quality standard, these products are fire rated, spark and friction tested.

Scotgrip® HD Stepmate® pipe/cable bridges and ramps are designed to be placed over the potential hazards of pipes, cables and hoses in the workplace. These products are lightweight for easy manual handling and can be used as a temporary measure or as a more permanent fixture. If required, we can incorporate protruding steel plates which can be welded to the deck as a permanent fixture. Scotgrip® HD Stepmate® bridges and ramps have been designed for pedestrian and light equipment use only.

- Eliminates 'Slips and Trips'
- Cost effective
- High traction anti-slip safety products
- Tough and durable
- Standard sizes and custom made
- Fully guaranteed
- Fire rated, spark and friction tested
- Non corrosive
- Easy to fit/lightweight construction
- Reflects positively on personnel performance

Step into a safer environment with Scotgrip®



PRODUCT DESCRIPTION

 Scotgrip® HD Stepmate® Pipe/Cable Bridge Ramps
 Scotgrip® HD Stepmate® General Purpose Ramps

CODE

 PCB1-5
 GP1-4

HIGH-TRACTION ANTI-SLIP

Scotgrip® HD Stepmate® ramp products will provide a sound foot-holding even in the most extreme conditions and will eliminate 'Slips and Trips' in your working environment.

SURFACE GRADES

 High Profile (super coarse) – 6mm aggregate (1/4" approx.)
 Low Profile (extra coarse) – 3mm aggregate (1/8" approx.)
 Fine Profile (coarse) – 1mm aggregate (1/16" approx.)

HIGHLY VISIBLE

 Colour coded in a wide range of colour schemes to suit individual locations.
 Colour codes are: Safety yellow, black/safety yellow, black, green, grey, blue, red, white.
 Photoluminescent marking is available
 Other colours available – please ask

HEAVY DUTY

Scotgrip® HD Stepmate® ramp safety products are extremely durable and will remain highly effective for many years.

STANDARD SIZES OR TO CUSTOMER SPECIFICATION

Scotgrip® HD Stepmate® ramp products are manufactured in a wide range of standard sizes (see table opposite). We regularly manufacture custom sizes to suit individual locations.

SAFETY MESSAGES/INFORMATION

Scotgrip® SignAlert® can be added to any of our Stepmate® range of ramps. Safety messages are proven to be an effective method of warning personnel of any hazards or hazardous areas they may be exposed to. Safety messages can be of any description and can even incorporate the clients company logo.

EASE OF INSTALLATION

Scotgrip® HD Stepmate® ramps can be placed into position quickly and easily due to their lightweight construction. Scotgrip® HD Stepmate® ramps have been designed for pedestrian and light equipment use only. If necessary weld tags can be built into the product at manufacturing stage.

QUALITY – IT'S WHAT DRIVES US

All Scotgrip® HD safety products are manufactured under BS EN ISO 9001:2015 quality controlled conditions using highly compatible raw materials at our premises in Banchory, UK.

FURTHER SCOTGRIP PRODUCTS

 If you would like to view the full Scotgrip® HD anti-slip & polyurethane safety product range, please look at our website: www.scotgrip.com where you will find all of our available products and details.

 Manufacturer: Scotgrip (UK) Limited
 Country of Origin: Scotland, UK

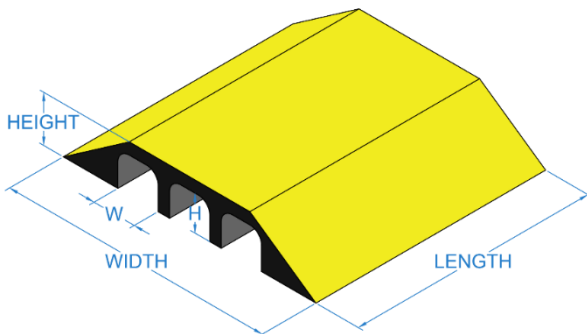
STEPMATE® PCB RAMPS (Pipe/Cable Bridge)

mm	inches	PCB1		PCB2		PCB3		PCB4		PCB5	
Width	380	15"	610	24"	750	30"	900	36"	1100	43"	
Height	80	3"	110	4"	140	5 1/2"	155	6"	200	8"	
Length	1000	40"	1000	40"	1000	40"	1000	40"	1000	40"	
Size of slots (3 No)	45w X 35h	1 3/4" w X 1 3/8" h	85w X 65h	3 3/8" w X 2 1/2" h	115w X 100h	4 1/2" w X 4" h	140w X 115h	5 1/2" w X 4 1/2" h	175w X 150h	7" w X 6" h	
Weight	10kg	22lbs	18kg	40lbs	24kg	53lbs	29kg	64lbs	36kg	80lbs	

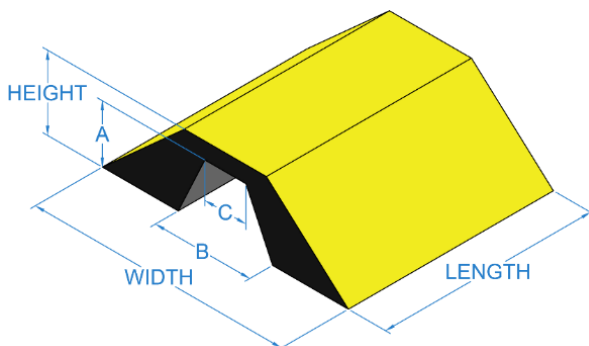
STEPMATE® GP RAMPS (General Purpose)

mm	inches	GP1		GP2		GP3		GP4	
Width	410	16"	450	18"	500	20"	600	24"	
Height	100	4"	125	5"	150	6"	180	7"	
Length	1000	40"	1000	40"	1000	40"	1000	40"	
a	75	3"	90	3 1/2"	115	4 1/2"	140	5 1/2"	
b	175	7"	180	7"	200	8"	230	9"	
c	100	4"	100	4"	100	4"	100	4"	
Weight	12kg	27lbs	14kg	40lbs	15kg	33lbs	17kg	38lbs	

 For further information or enquiries please contact us at info@scotgrip.com
UK Office (HQ)
Scotgrip (UK) Limited
 Silverbank Industrial Estate
 North Deeside Road, Banchory,
 Kincardineshire, AB31 5YR
 Scotland, UK
 Tel: +44 (0) 1330 825335

U.S. Office (Sales)
Scotgrip (UK) Limited
 Westchase Center
 2500 City West Boulevard
 Suite 300, Houston
 TX, 77042, USA
 Tel: +1 (713) 267 2243

Norway Office (Sales)
Norsk Industrivern AS
 Skurvebakkane 32
 N-4330, Algard
 Norway
 Tel: +47 5171 5600